

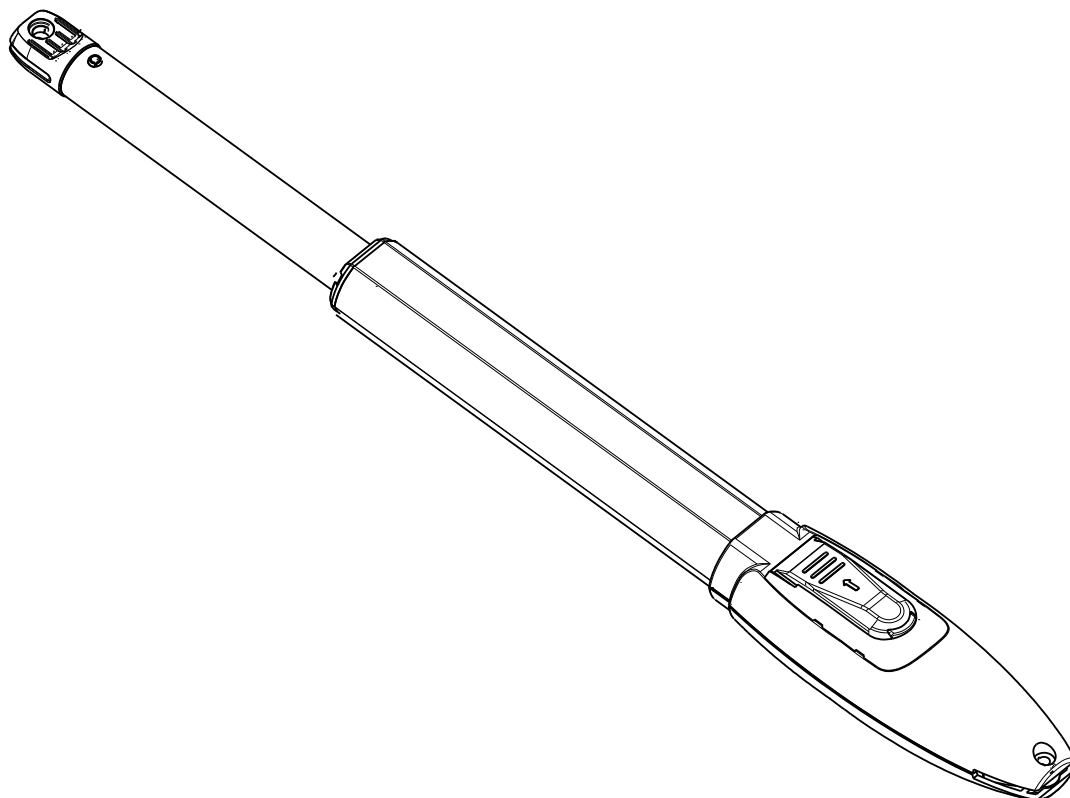

SWG3100/SWG3101 DC Swing Gate Opener User Manual



CONTENTS:

1. Safety Instruction	1
2. Packing List	2
3. Technical Parameters	3
4. Installation	4
4.1 Installation Drawing	4
4.2 Size of Main Machine and Mounting Bracket	4
4.2.1 Size of Main Machine	4
4.2.2 Size of Mounting Bracket	5
4.3 Installation Steps	5
4.3.1 Preparation before Main Machine Installation	5
4.3.2 Accessory Installation.....	5
4.3.3 Main Machine Installation	7
4.3.4 Size of Control Box.....	9
5. Wiring and Debugging	10
5.1 Wiring Instructions	10
5.2 Control Board Drawing and Instructions	10
5.3 Inputs Status	12
5.4 Travel Setting	12
5.5 Trimmers Setting	13
5.6 Learning Transmitter & Delete Transmitter	13
5.7 Control Board Settings	14
5.8 Base Menu	14
5.9 Advance Menu	16
5.10 Infrared Photocell Connection (Optional)	20
5.11 Solar Panel Connection (Optional)	21
6. Others	19
6.1 Maintenance	19
6.2 Troubleshooting	19

Dear users,





Thank you for choosing this product. Please read the manual carefully before assembling and using it. Please do not leave out the manual if you send this product to a third party.

1. Safety Instruction

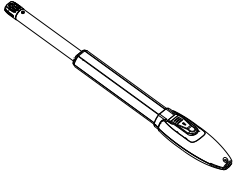

- Please read this manual carefully before installation, in which involves with important information about installation、 using、 maintenance and safety.
- Any undefined operations under this manual is not allowed, incorrect using may damage the product even causing the injuries or property losses.
- To consider the possible danger during the installation or using process of swing gate operator, installation must strictly comply with the construction standard and electrical operating procedure.
- Before installation, please make sure that the power voltage being used matches with the supply voltage of this product. Please check if the leakage protection switch is installed and the grounding system is correct.
- Please check if additional equipments or materials are required to meet the specific requirements.
- The disposal of packaging material must be complying with the local regulation.
- Please do not change any parts except for those defined under this manual. Any undefined changes may cause the malfunction. Any damages to the product arising therefrom shall be beyond the liability of the company.
- Please do not leak water or any liquid into the controller or any other open devices. Please disconnect the power immediately if any mentioned cases happened.
- Please keep this product away from heat and open fire. Or it may damage the components; cause the failure or other hazards.
- Please make sure there is no vehicles、 passengers and objects passing through while the swing gate is moving.
- Anti-clip equipment like infrared protection switch must be installed to avoid injuries to person and property losses. The company shall not be liable for any damage or accident arising therefrom.
- The installation、 using and maintenance of this product must be carried out by professionals.
- Children are not allowed be touch the control devices or remote transmitters.
- A warning sign must be placed somewhere on the swing gate according to the national standard.
- Please keep this instruction properly for future reference.

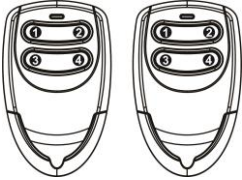
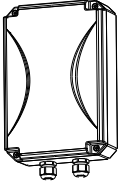
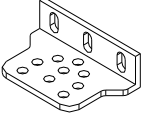
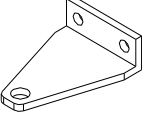
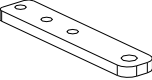
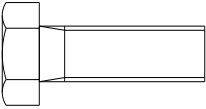
2. Packing List (Standard)

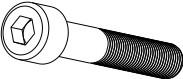
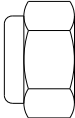
No.	Picture	Name	Quantity
1		Main machine	2
2		Manual release key	2
3		Remote control	2
4		Control box	1
5		Wall bracket	4
6		Front mounting bracket	2
7		Connecting bracket	2
8		Screw M8X25	4
9		Mounting screw (short)	2
10		Screw M8x45	2
11		Self-locking Nut M8	8

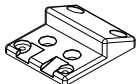
No.	Picture	Name	Quantity
12		Limit stopper	1

Packing List (Optional)

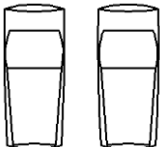
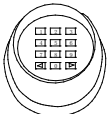
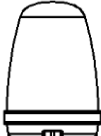
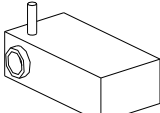
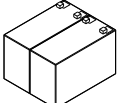
No.	Picture	Name	Quantity
1		Infrared sensor	1
2		Wireless keypad	1
3		Alarm lamp	1
4		Electric lock	1
5		Storage battery	2

3. Technical Parameters

Model	SWG3100	SWG3101
Power supply	220V/50Hz	110V/60Hz
Motor power	50W	50W
Gate moving speed	18~22s / 90°	18~22s / 90°
Max.single-leaf weight	300kg	300kg
Max.single-leaf length	2.5M	2.5M
Max.piston stroke	32cm	32cm
Max.force	2800N	2800N
Remote control distance	≥30m	≥30m
Remote control mode	Single/Four button mode	Single/Four button mode
Storage battery (optional)	DC24V (4.5Ah or 9Ah)	DC24V (4.5Ah or 9Ah)
Noise	≤58dB	≤58dB

Recording of up remote controls	32	32
Remote frequency	433.92 MHz	433.92 MHz
Working temperature	-20°C - +70°C	-20°C - +70°C
Package weight	14kg	14kg

4. Installation

SWG3100/SWG3101 swing gate opener is applicable to single leaf gate weight less than 300kg, and the length shorter than 2.5m. The drive mode adopts planetary transmission to combine with the screw rod transmission. This gate opener must be installed inside the enclosure or yard for protection.

4.1 Installation Drawing

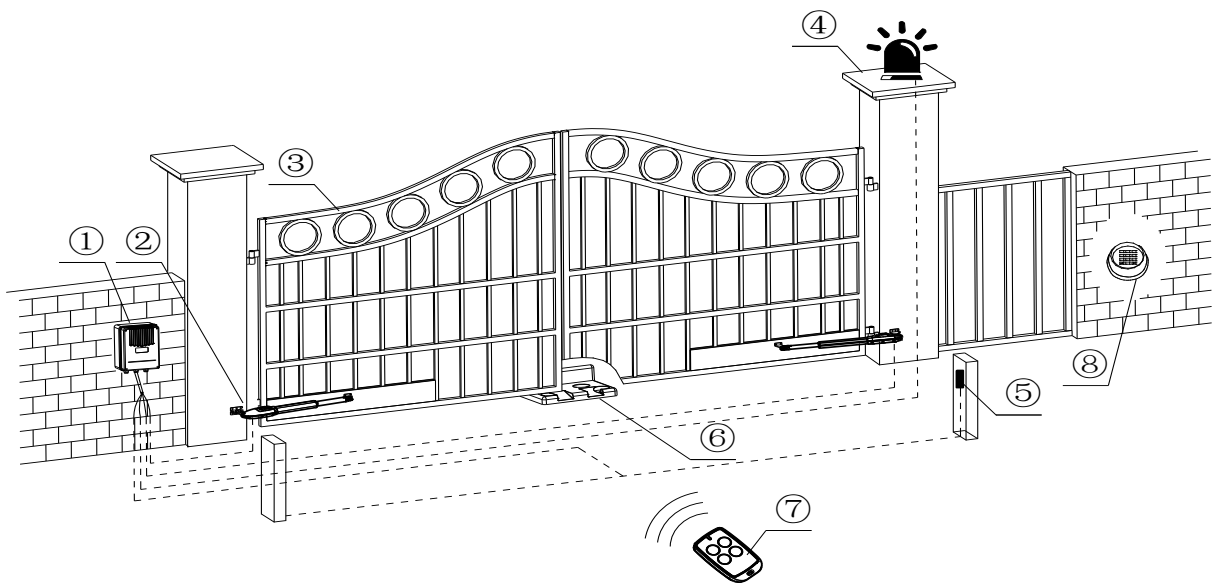

Figure 1

- ① Control box
- ② Gate opener
- ③ Gate
- ④ Alarm lamp (optional)
- ⑤ Infrared sensor (optional)
- ⑥ Limit stopper
- ⑦ Remote control
- ⑧ Wireless keypad (optional)

4.2 Size of Main Machine and Mounting Bracket

4.2.1 Size of Main Machine

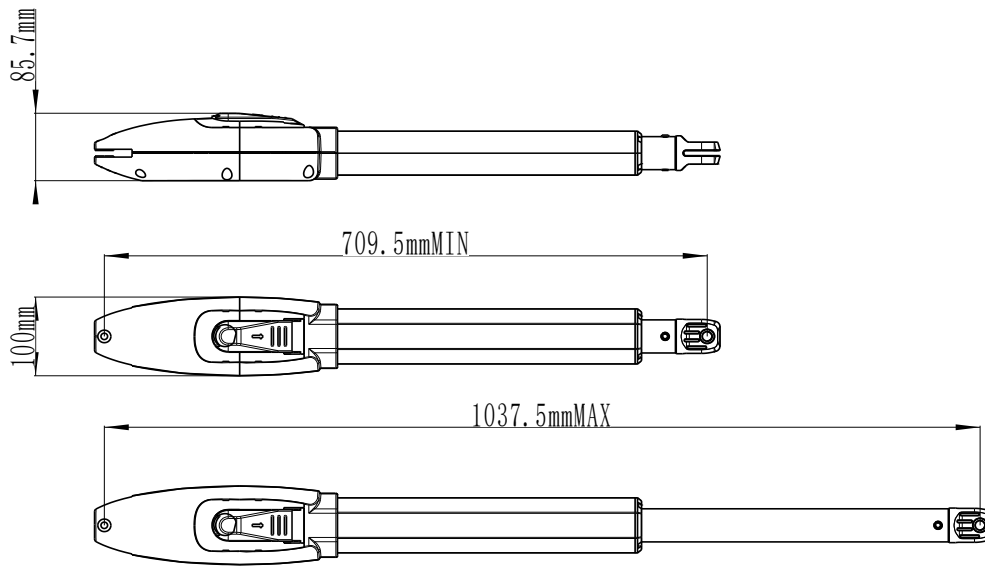
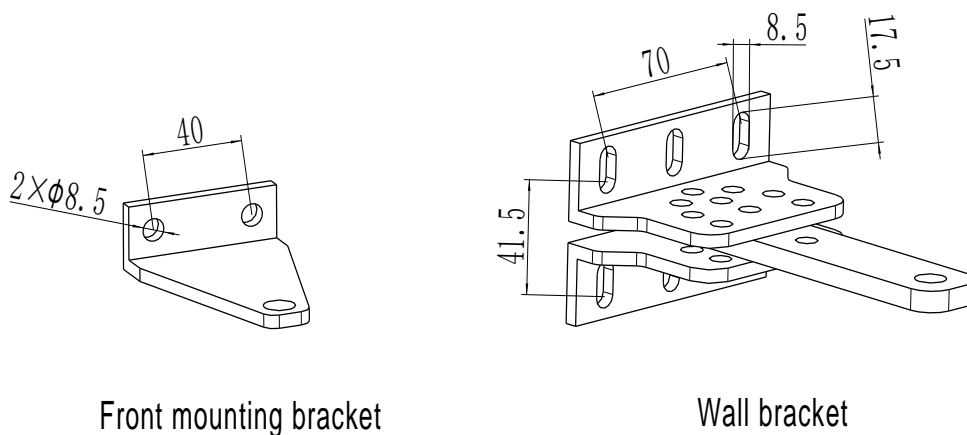

Figure 2

4.2.2 Size of Mounting Bracket



Front mounting bracket

Wall bracket

Figure 3

4.3 Installation Steps

4.3.1 Preparation before Main Machine Installation

- a) Before installing the door opener, please confirm that the doors were installed correctly, please ensure that the door can be manually operated smoothly, and the door safety stopper can effectively prevent the door to continue moving.
- b) Please keep a distance of 45-50mm between the door bottom and the ground for installing the electric lock. If electric lock is not required, the distance between the door bottom and the ground should be ≥ 20 mm;
- c) The recommended mounting height of the 2 main machines is around 300 ~ 800mm above the ground, and make sure there are reliable fixed points for mounting brackets.

Cable bury

In order to ensure the normal operation of the door opener and protect the cable from damage, please use two PVC

pipes to bury the motor and power cables, and the control cables separately. One PVC pipe for motor and power cables, the other one for control cables.

Mounting brackets fixing

In order to install the SWG3100/SWG3101 main machines firmly, it is recommended to use the expansion screws to fix the mounting brackets.

4.3.2 Accessory Installation

a) Before installing the main machines, please install the wall bracket on the wall first, then fix the connecting bracket, finally install the front mounting bracket on the door.

Note: Please detect by gradienter before fixing to ensure that the front mounting bracket and the connecting bracket are in the same level.

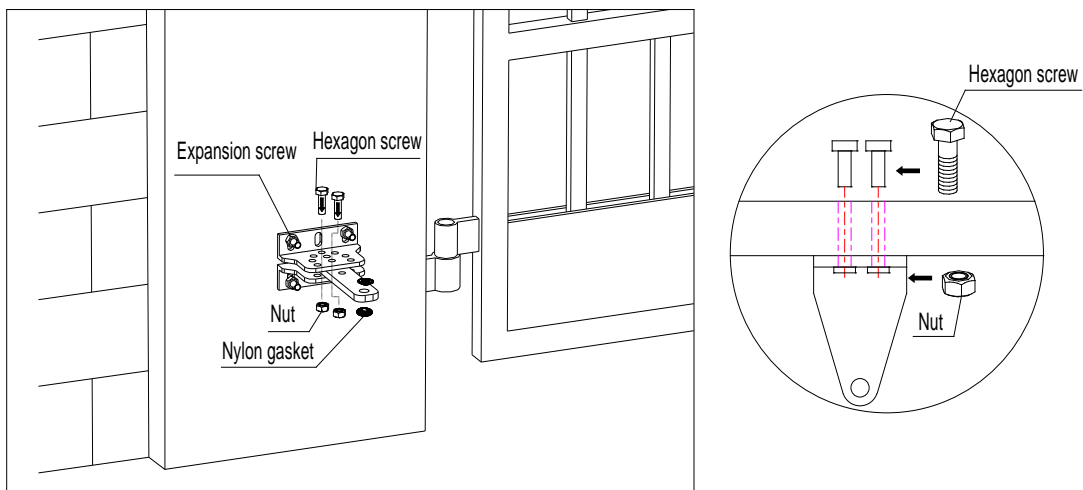

Figure 4

b) The connecting bracket and the wall bracket can be connected according to different conditions, please refer to figure 5.

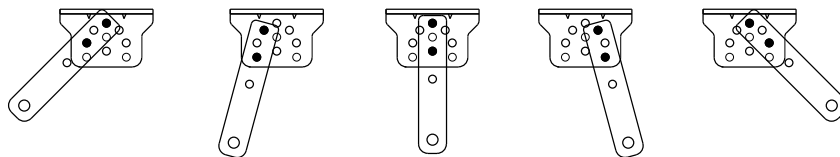

Figure 5

c) Users should prepare power cables for the control box and the main machines by themselves due to the different installation environment. The cores for the control box power supply cable should be more than 3, the cores for the motor cable is 2. If users need to install external accessories like electric lock, infrared sensor, alarm lamp, external button switch etc., please increase the embedded cables accordingly, please make sure the sectional diameter of electric lock cable is over 1.5mm², sectional diameter of other cables is over 0.5mm². The cable length should be determined by users according to their installation situations.

Note: The outlet on the PVC pipe should be downward in order to avoid the rain water flowing into the pipe

along the cable.

d) Before the installation, please unlock the two main machines. Unlock method: Open the manual release cover, insert the manual release key, rotate the key until it's released, as shown in Figure 6, then turn the telescopic arm, you'll find it is stretched easily.

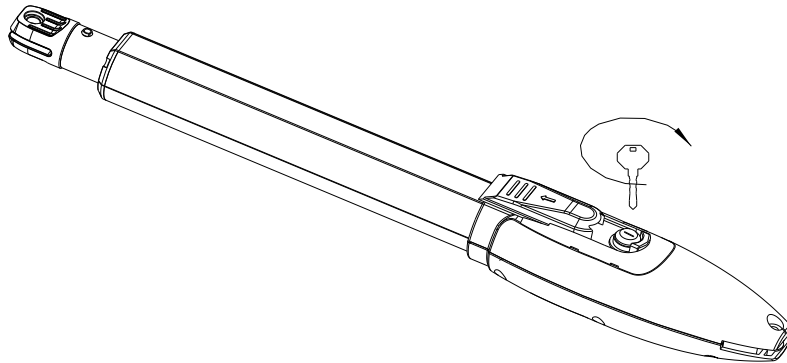

Figure 6

4.3.3 Main Machine Installation

Please refer to Figure 7 to fix the tail of the main machine and the connecting bracket with the installation screws, and then manually adjust the telescopic arm to the appropriate length, finally fix the telescopic arm connector and the front mounting bracket with the installation screws. Pull the door after installation to ensure the travel is flexible without jamming.

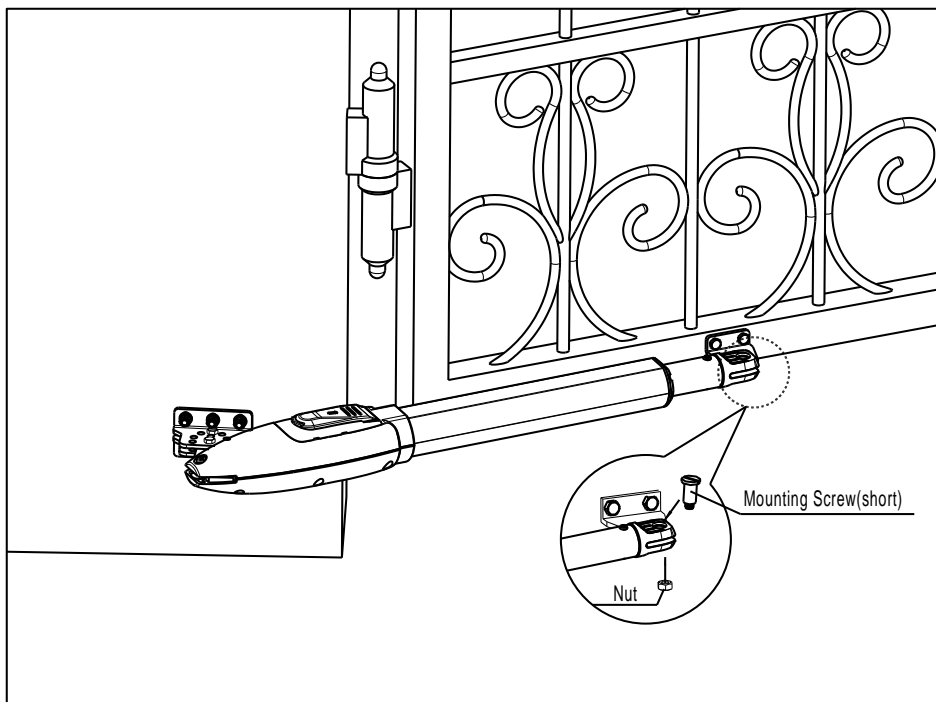

Figure 7

Installation direction: door opens inward

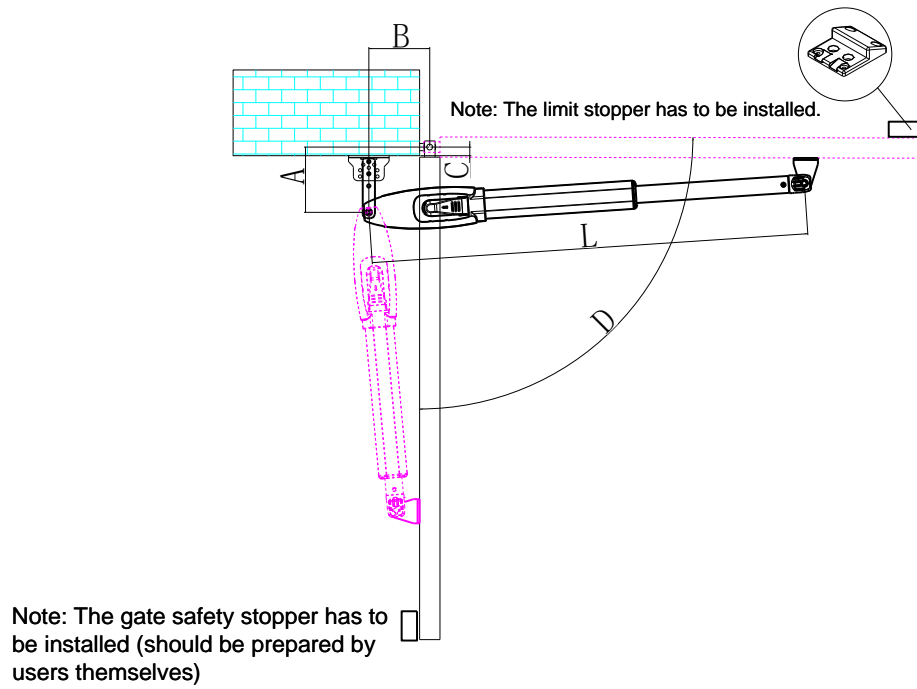

Figure 8

	A	B	C	D	L
SIZE(mm)	100	200	-40	100°	1040
	120	180	-20	100°	1040
	140	160	0	100°	1040
	160	140	20	100°	1040

Table 1 Recommended Installation Position

Note: Value B must be close or equal to the value A to reach the best mechanical advantage.

Installation direction: door opens outward

Note: The gate safety stopper has to be installed (should be prepared by users themselves)

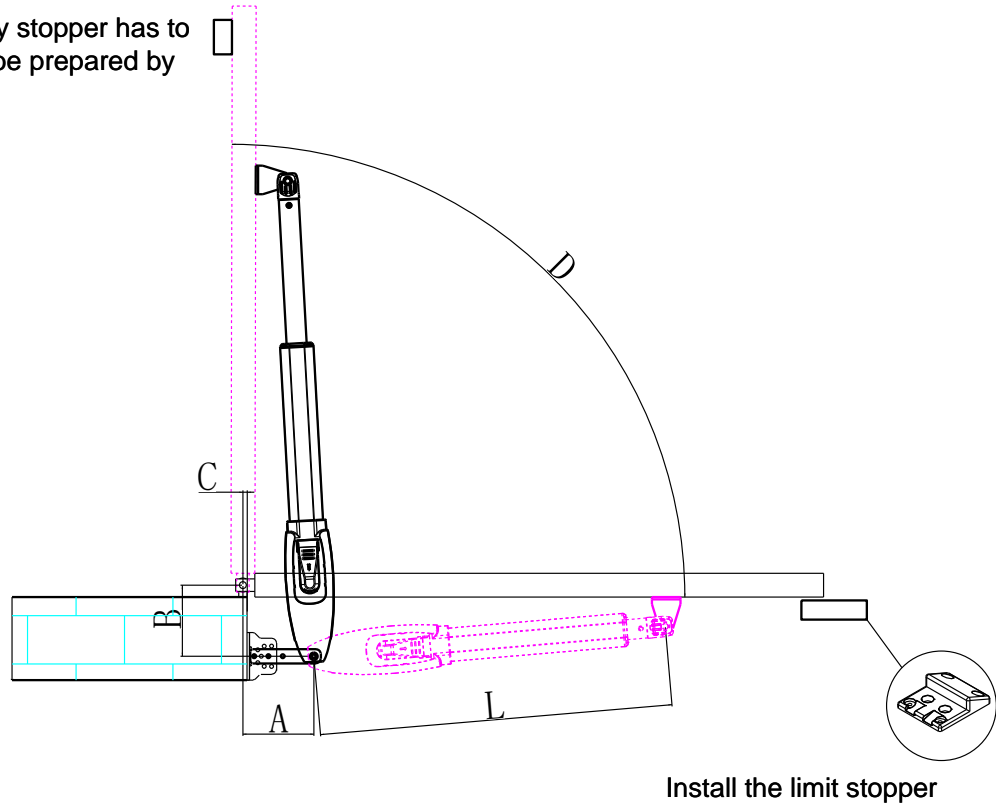

Figure 9

	A	B	C	D	L
SIZE(mm)	200	100	60	95°	711
	180	120	40	100°	711
	160	140	20	100°	711
	140	180	0	95°	711

Table 2 Recommended Installation Position

Note: Value B must be close or equal to the value A to reach the best mechanical advantage.

4.3.4 Size of Control Box

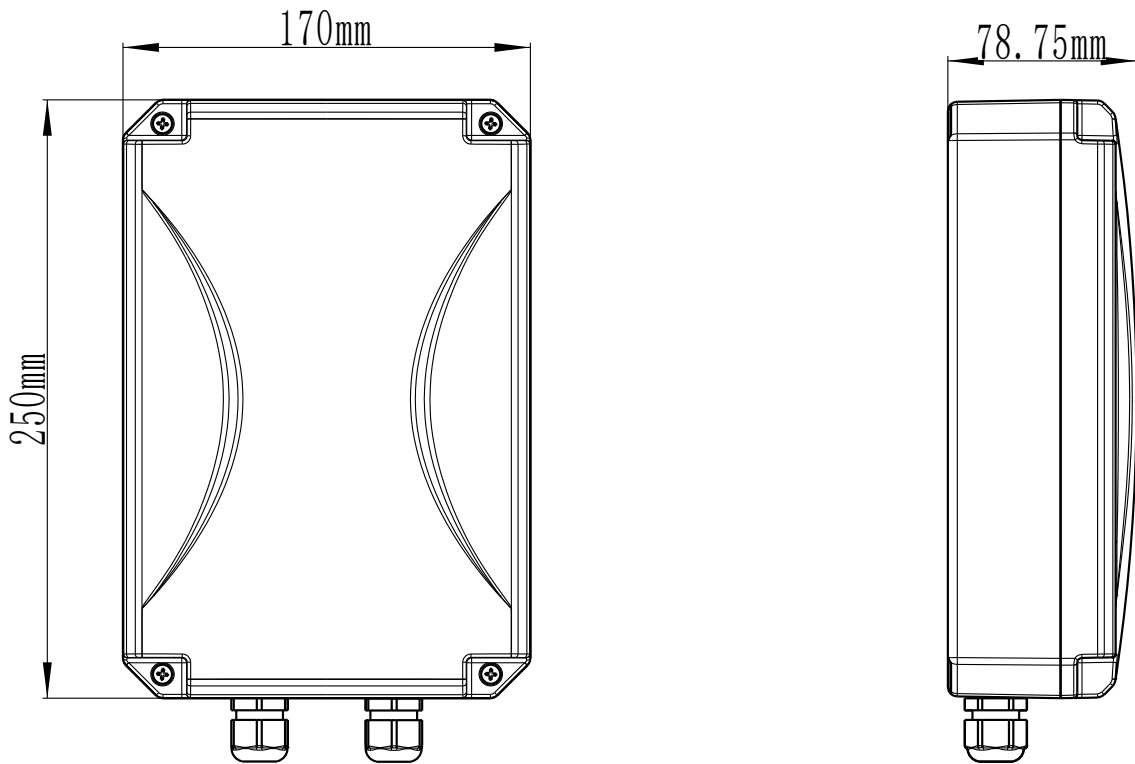

Figure 10



Warning

- To ensure safety and protect the machines, please install a gate stopper at the open limit position when the door opens outward to prevent the gate from running over its travel. Meanwhile, to enable the 2 swings to close to its accurate limit position, please install a limit stopper at the close limit position (as shown in figure 9). Similarly, when the door opens inward, please install a limit stopper at the close limit position (as shown in figure 8).
- Before installing the main machine, please make sure the main machine and components are in good mechanical performance and the door can be manually operated flexibly.
- One control unit can optionally drive one main machine or two main machines.
- Earth leakage circuit breaker must be installed on where the gate movement can be seen, and the minimum mounting height for the control box should be over 1.5m to avoid being touched by kids.
- After installation, please check whether the mechanical property is good or not, whether gate movement is flexible or not after unlocking, and whether the infrared sensor (optional) is installed correctly and effectively.

5. Wiring and Debugging

5.1 Wiring Instructions

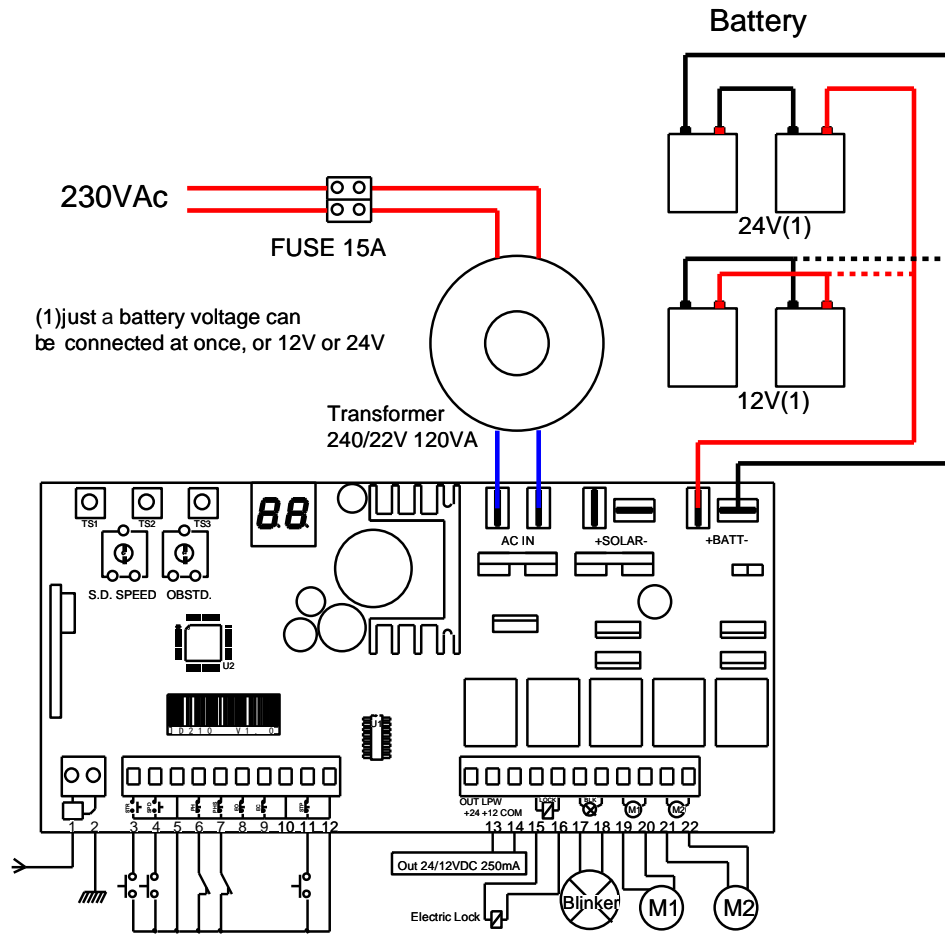

Figure 11

5.2 Control Board Drawing and Instructions

Drawing:

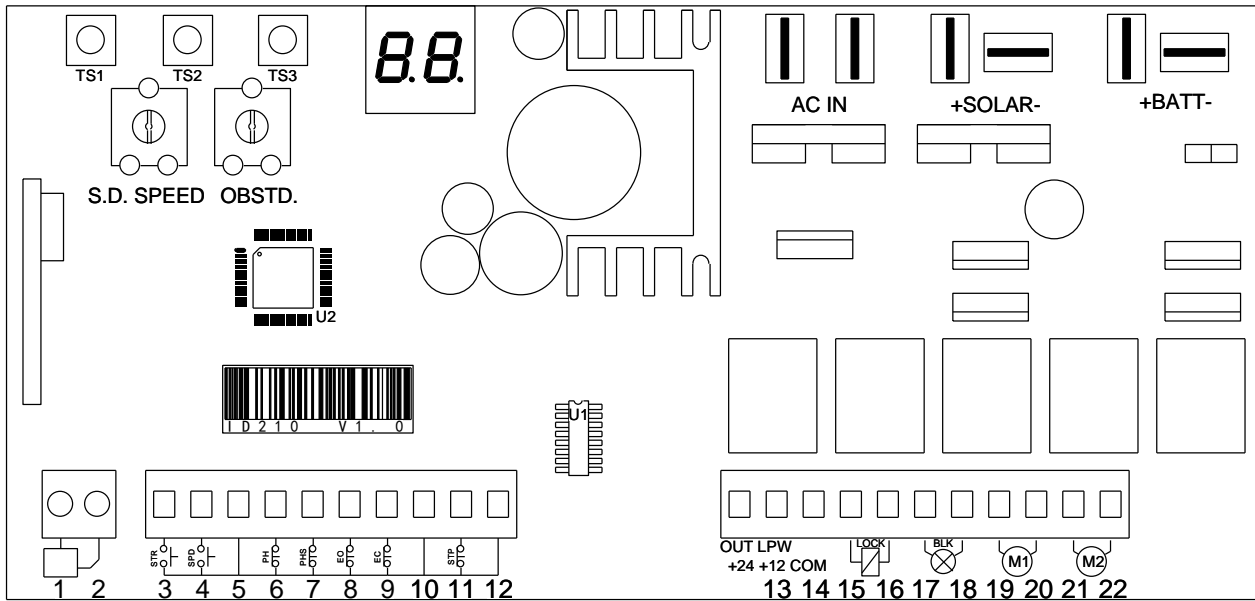

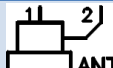









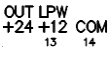



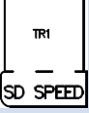
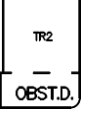
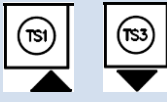



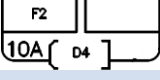
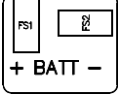



Figure 12

Instructions:

Terminal	Remarks
1. Antenna 	
2. Antenna's shield 	
3. Start input (NO) 	It completely opens the gate
4. Pedestrian start in. (NO) 	It opens just motor 2
5. Common 	
6. Photocell input (NC) 	During pause: Reloads pause During closing: Reverses motors direction
7. Photo stop input (NC) 	During pause: Reloads pause. During closing: Reverses motors direction. During opening: stops the motors and waits till contact returns close.
8. Analog opening edge input (8K2 ohm) 	Waiting an opening command: inhibits opening During opening: reverses motor direction for 1 second. If not used left unconnected.
9. Analog closing edge input (8K2 ohm) 	Waiting a closing command: inhibits closing. During closing: reverses motor direction for 1 second. If not used left unconnected.
10. Common 	

11. Stop input (NC)		It always stops motors and blocks control unit activity.
12. Common		
Space-13-14. Power supply output		24V/12Vdc 250mA
15-16. Electric lock output		12/24V 1A (fix on MOT2)
17-18. Flashing light output		12/24V 1A
19-20. Output motor 1		8A
21-22. Output motor 2		8A
TR1.		Slowing down speed trimmer
TR2.		Obstacle detection sensibility trimmer
TS1-TS3.		Buttons up/down
TS2.		Enter button
DSP.		Display
FS3-FS4.		Transformer input 12-20Vac / 100-200VA
F2. Battery fuse 10A Fast		The default is 24VDC.
FS1-FS2.		Backup battery input 12/24VDC
J1.		Back up battery voltage selector 12/24V

5.3 Inputs Status

When the control unit is in standby. User can read inputs status on display:

__: No input active.

ST: Stop input active.

P5: Photo stop input active.

PC: Photocells input active.

EO: Analogic edge opening input active.

EC: Analogic edge closing input active.

SB: Start input active.

SP: Pedestrian input active.

OP: Open input active.

CL: close input active.

During pause, the display shows the seconds countdown to closing.

5.4 Travel Setting (VERY IMPORTANT)

After the first time installation but before starting normal operation, one important step you have to take it to set the opening and closing limit stop positions for the running travel.

Please unlock the actuator first, manually swing the 2 doors to fully opened position then lock the actuator. Press and

hold 'TS1' button on the PC board till you read  on the display. The door will open and stop in the opened position for 5 seconds (PC board is learning the rotor-locked current value), then door will close automatically. After the 2 swings are fully closed and display showing '--', running travel setting is finished. Please verify the correct installation by pressing the opening/closing button on the remote transmitter.

Slow stop is activated after travel setting, if slow stop speed is too slow, please adjust 'TR1' to increase. If slow stop speed is too fast, please adjust 'TR1' to decrease.

Note: If the door is no need to be fully opened, please install the limit stopper at the proper position.

5.5 Trimmers Setting

Slow down speed trimmer regulates the slowdown speed. Do not set speed to low (less than 10 cm/sec on the wing edge) to avoid that gate stops in too cold conditions.

Obstacle sensibility trimmer fine tunes the obstacle detection level learned by the control unit during working times programming. This fine regulation must be do after working times learning.

Normally the trimmer goes in the center, in this position should be possible to respect rules in most of installations. If it's need to resolve problems related to norms or to environmental situations (ex. Strong wind) is it possible to regulate this trimmer increasing or decreasing sensibility.

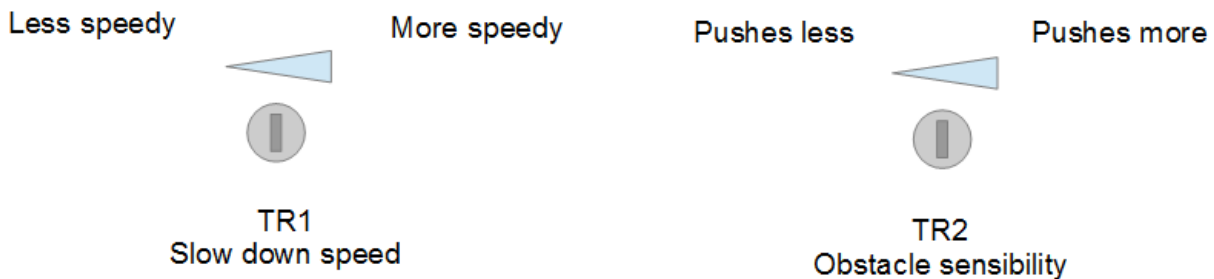

Figure 13

5.6 Learning Transmitter & Delete Transmitter

Press button TS3, display shows C1, press the button you want to program, and until display shows digital, learning is

finished. (The default remote control mode is Step by Step)

Press button **TS3** and hold on until display shows **OK**, all the remotes have been deleted.

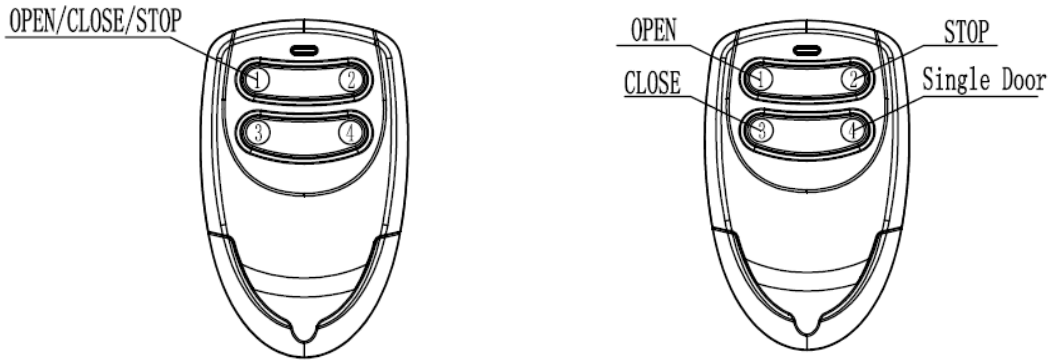

Single button mode remote control

Four button mode remote control R3

Figure 14

5.7 Control Board Settings

Base Menu

Push enter 1 for at least 1 second to enter base menu.

OL is on the display, with up/down it's possible to select other functions of this menu.

To exit this menu select **EX** or push up and down together.

After 2 minutes without actions, the control unit exits itself from this menu.

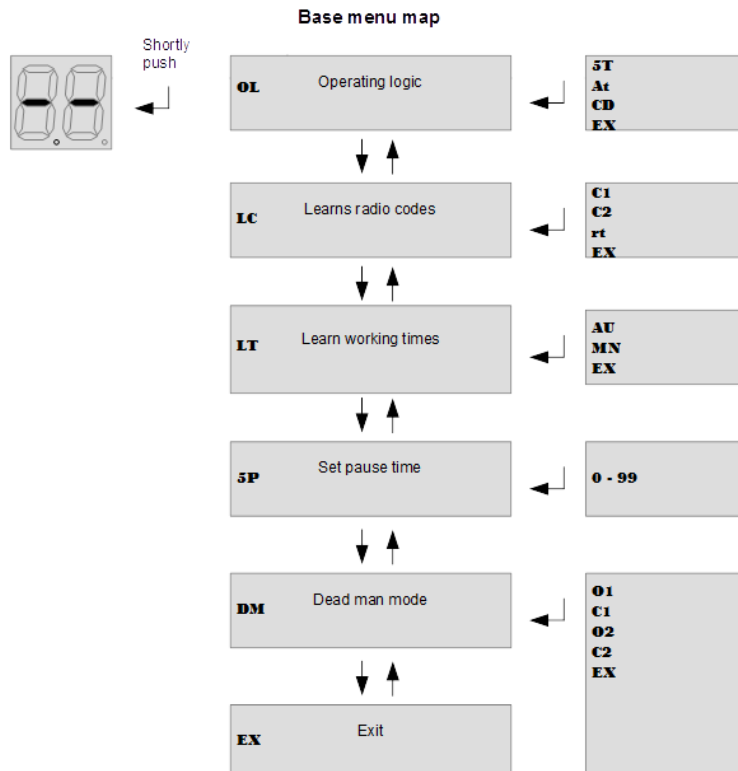

Figure 15

5.8 Base Menu

Operating logic **OL**:

Select **OL** and push enter, with up/down select wanted logic between following end push once enter. Check tab operating logic for further information.

5T: Step by step logic.

At: Automatic closing with stop function.

CD: Automatic closing for condominium function.

To exit this menu select **EX** or push up/down together.

LC Learning/ removing transmitters code:

Select learning code function **LC** and push enter, than select one of following functions with up/down.

C1: learn a transmitter on channel1.

C2: learn a transmitter on channel2.

Rt: Delete all transmitter in memory.

Once selected the channel transmit the code, on the display is show "**OK**" for a while if operation is done.

To replace the channel of a code, just select desired channel and transmit once the same code.

To delete just one code, select **RT** and transmit the code to be removed, on the display is show "**OK**" for a while if operation is done.

To delete all codes, select **RT** and push enter, then confirm with **YS**.

To exit this menu select **EX** or push up/down together.

LT learn working time:

Attention: before to start learning procedure, the gate must be open to do automatic procedure, otherwise must be closed to do the manual procedure. Use "dead man " function to put the gate in the right position.

Is it possible to program working time automatically, please refer to "**Quick installation**"

Select **LT** in the base menu and push enter, after select the learning mode with up/down.

AU: automatic learning procedure.

MN: Manual learning procedure.

To exit this menu select **EX** or push up/down together.

AU: Automatic procedure for working times learning.

Attention: in this procedure all safety inputs are disabled.

The wings close themselves, in the meanwhile all the working times and values for obstacle

detection sensor are learned. If just motor 2 is connected, the control unit sets itself for "single wing working". If analogue edges are connected, they are automatically enabled.

5p Set pause times:

Use up/down to set the pause time between 0 and 99 seconds. Push enter to confirm. To exit without modifications push together up and down.

Attention: setting pause time doesn't enable auto closing, please refer to chapter "OL operating logic" to enable this function.

DM Dead man mode:

Selecting this menu it's possible to control each motor in dead man mode. Push up and down to select one of following item:

O1 open motor1

C1 close motor1

Q1 open motor2

C2 close motor2

EX Exit

Keep pushed enter to start the selected motor in dead man mode.

5.9 Advance Menu

Push enter button till on the display is shown **TM**. With up/down it's possible to select all items in this menu.

To exit this menu select **EX** or push up/down together.

After 2 minutes without actions, control unit exits itself from this menu.

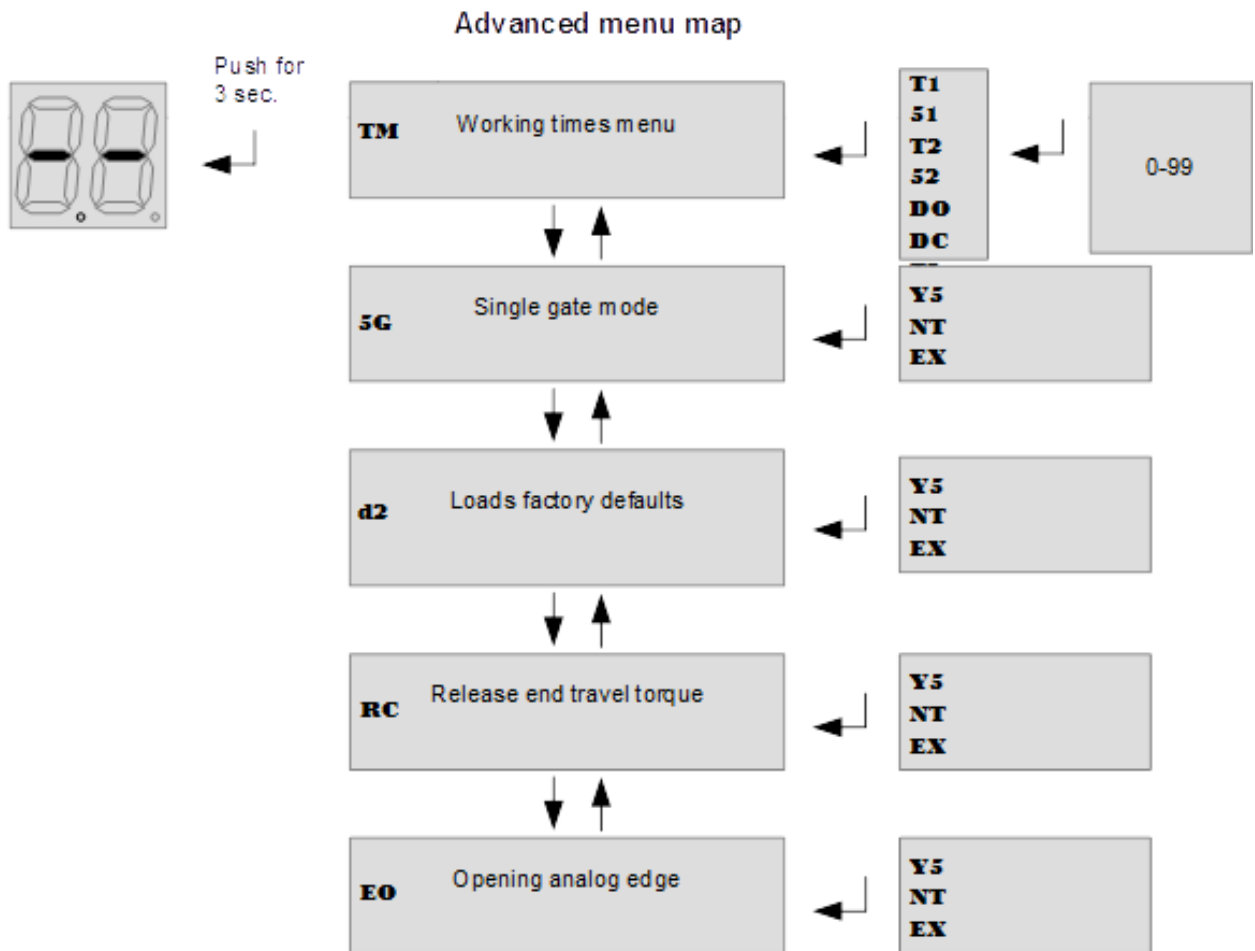

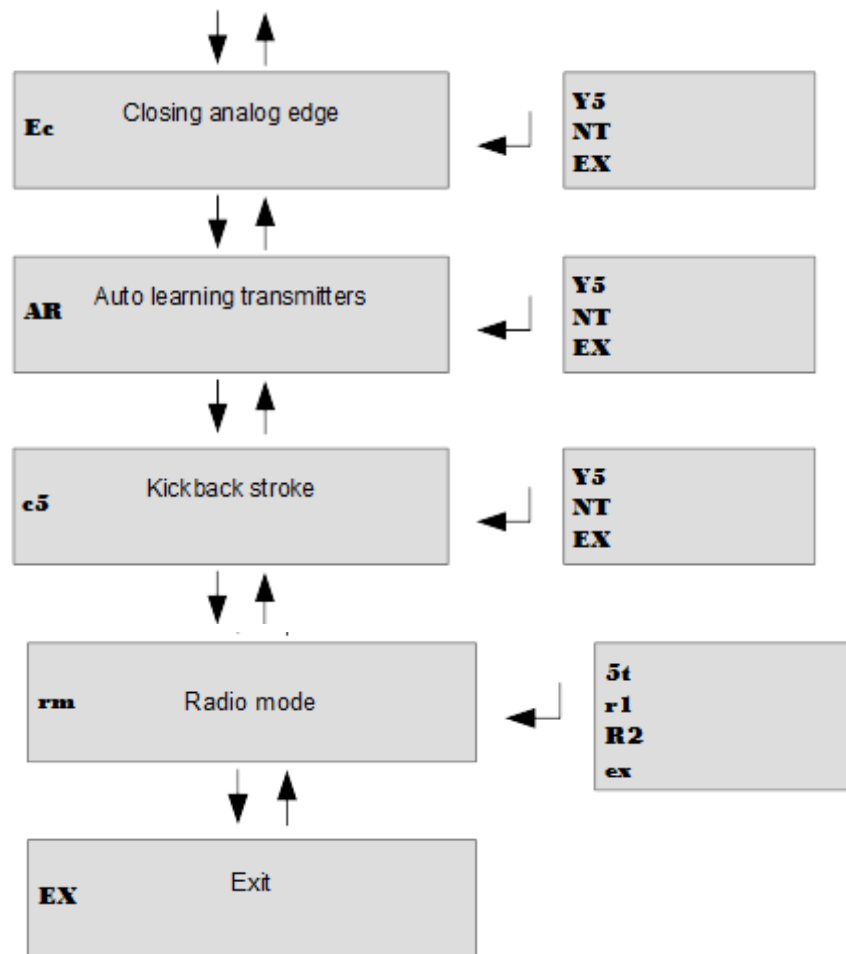

Figure 16

Advance menu description:

TM working times menu:

In this menu it's possible to modify working times of control unit:

T1- Working time motor1

51- Start time slowdown motor1

T2- Working time motor2

52- Start time slowdown motor2

DO- Motors delay opening

DC- Motors delay closing

TL-Electric lock activation menu.

EX-Exits from advanced menu.

Once selected working times to be changed, use up/down to modify it from 0 to 99 seconds. Push enter to confirm.

To exit without modifications select EH or push together up and down.

5G Single wing mode:

In this menu it's possible to verify or set if gate works in single wing mode (motor2). Use up/down to choose yes (YS), not (NT) or exit(EX). Push enter to confirm.

D2 Load defaults:

Choosing this menu and confirming with yes (YS), set the control unit at factory defaults.

RC release torque at work end:

Enabling this function, the motors reverse direction for a while to release the torque at end of work .Use up/down to choose yes(YS),not (NT) or exit(EX). Push enter to confirm.

EO Enable opening analogue edge:

Enabling this function it's enabled the edge active in opening period. Choose yes(YS) is enables the edge.

EC Enable closing analogue edge:

Enabling this function it's enabled the edge active in closing period. Choose yes(YS) is enables the edge.

Ar Enable automatic transmitters learning:

Enabling this function it's possible to insert new transmitters without accessing base menu. Refer to "Automatic transmitters learning".

C5 Enable kickback stroke:

In this menu you can enabled the stroke at start to unlock electric lock and the final stroke to lock it.

rM Radio mode:

In this menu it's possible to modify how transmitters work with the control unit.

5T- Step by step mode: Each button (code) of the transmitter is entered separated by the others, Codes learned on C1 work as "Start command". Transmitters learned on C2 word as "Pedestrian command".

r1- Learning a code from a transmitter, it enables all the four buttons of transmitter wording with the control unit. Sequence is: Button1=open command, Button2=close commend, Button3=Pedestrian commend, Button 4=stop commend.

r2- Learning a code from a transmitter, it enables all the four buttons of transmitter wording with the control unit. The sequence is as above, except buttons3 and 4 inverted.

Default settings (Factory presets)

Here it follows list default settings. The same set after a **D2** command of advanced menu.

Setting	Default
0L Operating logic	5T Step by step
5P Pause time	10 10 seconds
T1 Working time motor 1-2 T2	30 30 seconds
51 Slowing down time motor 1-2 52	20 20 seconds
D0 Wings delay opening	02 2 seconds
Dc Wings delay closing	05 5 seconds
TL Electric lock activation time	02 2 seconds
5G Single gate mode	NT Not
RC Release end travel torque	NT Not
E0 Opening analog edge	NT Not
EC Closing analog edge	NT Not
AT Auto learning transmitters	Y5 Yes
rm Radio mode	5T Step by step
C5 Kickback stroke	NT Not

Figure 17

5.10 Infrared Photocell Connection (Optional)

Before connecting the infrared photocell, please remove the jumper wire between terminal 5 and 6 first.

Infrared photocell function: To protect passengers or property from clipping, during gate closing, once infrared photocell ray is cut, the gate will open immediately.

The distance between photocell receiver and emitter should not be less than 2 meters, otherwise will affect the induction of the photocell.

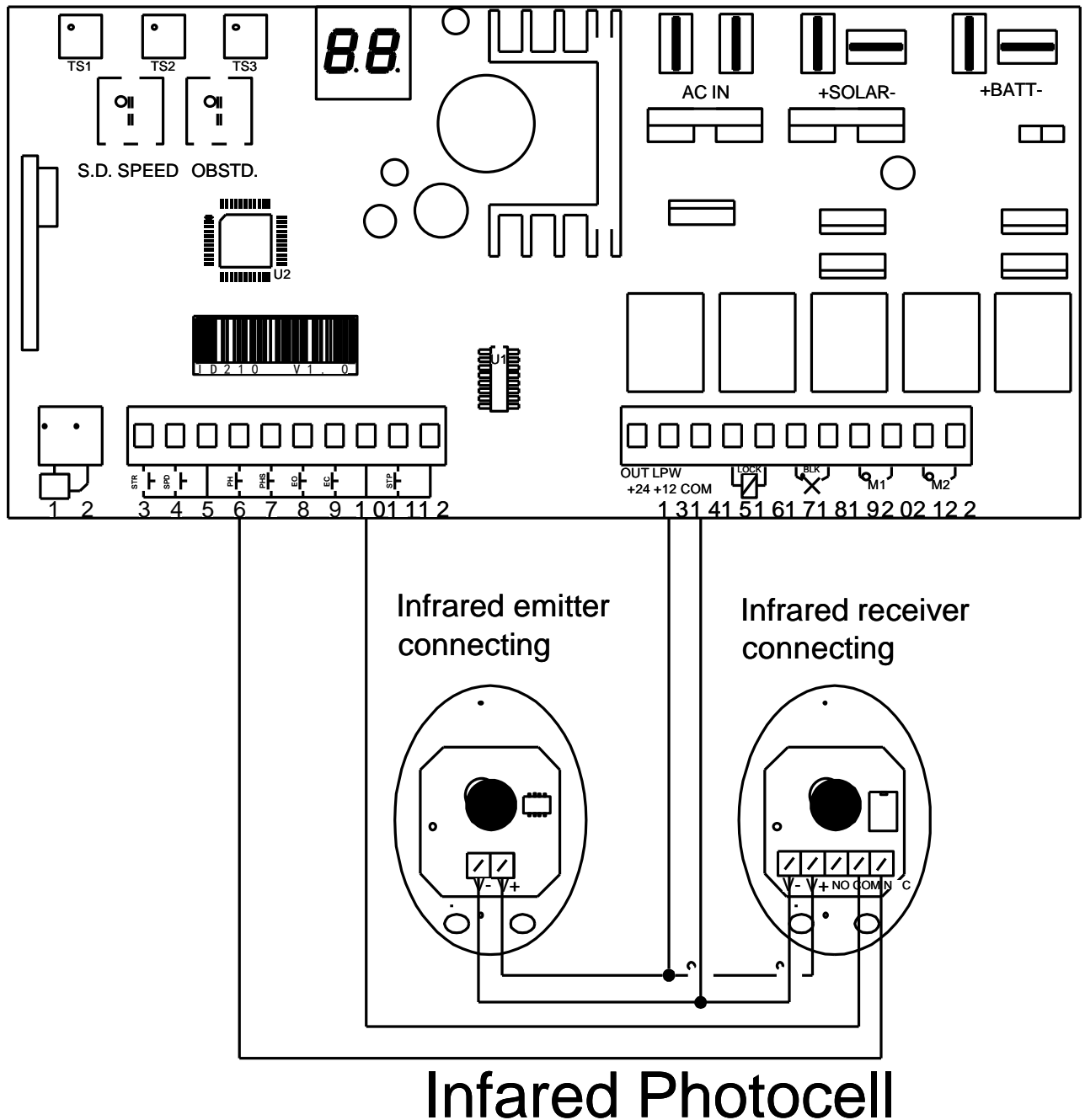

Figure 18

5.11 Solar Panel Connection (Optional)

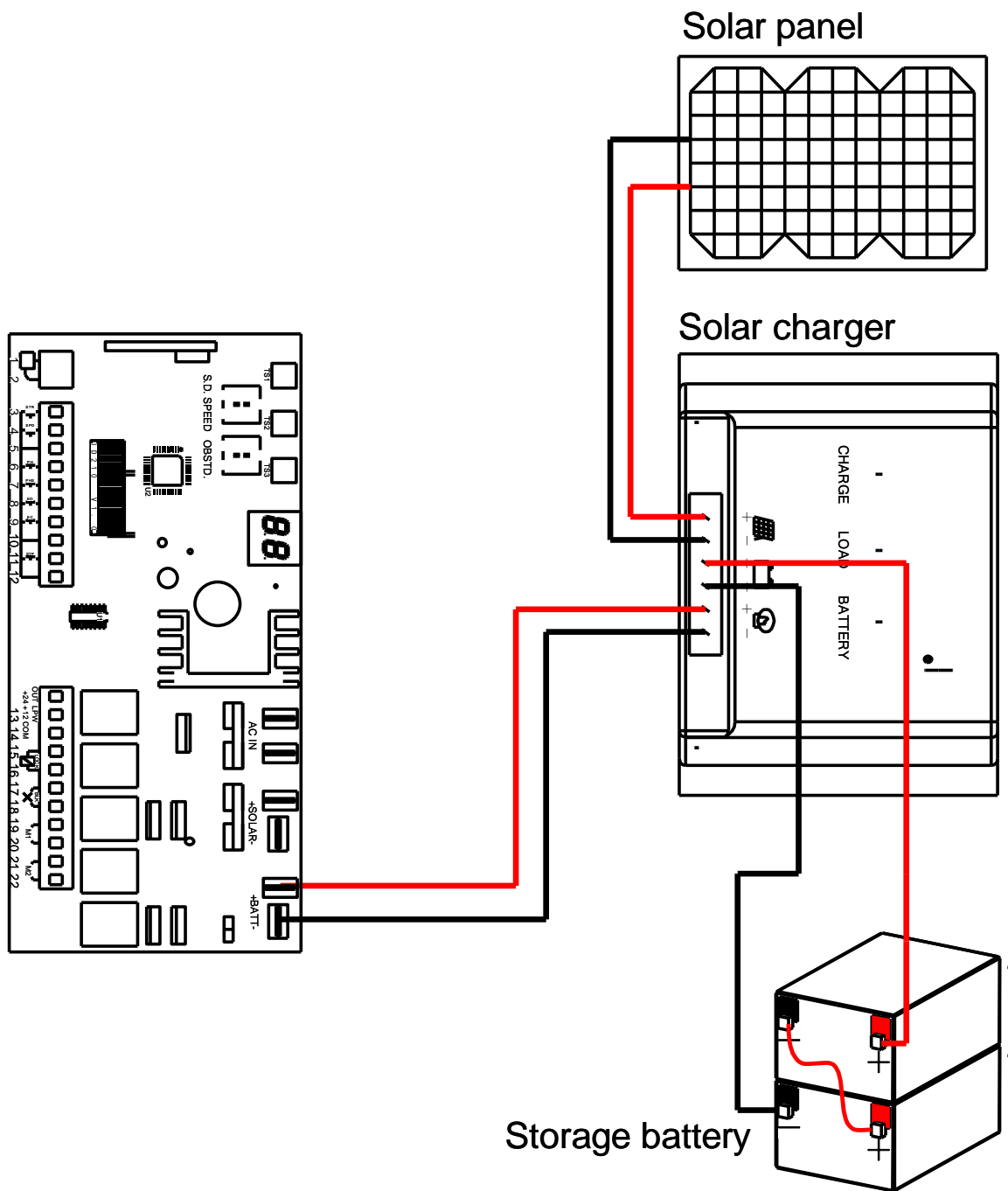

Figure 19

6. Others

6.1 Maintenance

Check whether the gate operates normally every month.

For the sake of safety, each gate is suggested to be equipped with infrared protector, and regular inspection is required as well.

Before installation and operation of the gate opener, please read all instructions carefully.

We reserve the right to change the instruction without prior notice.

6.2 Troubleshooting

Problems	Possible Reasons	Solutions
The gate cannot open or close normally, and Display does not light.	<ol style="list-style-type: none"> 1.The power is off. 2.Fuse is burned. 3.Control board power wiring with problem. 	<ol style="list-style-type: none"> 1.Switch on the power supply. 2.Check the fuse, change the fuse if burnt. 3.Re wiring according to instructions.
The gate can open but cannot close.	<ol style="list-style-type: none"> 1.Photocell wiring with problem. 2.Photocell mounting with problem. 3.Photocell is blocked by objects. 4.Sensitivity of obstacle is too high. 	<ol style="list-style-type: none"> 1.If not connect photocell, please make sure that the 5 and 6, 5 and 7 short circuit; if connect infrared sensor, please make sure the wiring is correct and the photocell is N.C. 2.Make sure that the photocell mounting position can be mutually aligned. 3.Remove the obstacle. 4.Reduce the sensitivity of obstacle.
Remote control doesn't work.	<ol style="list-style-type: none"> 1.Battery level of the remote control is low. 2.Remote control learning is not completed. 	<ol style="list-style-type: none"> 1.Change the remote control battery. 2.Re-conduct remote control learning.
Press OPEN, CLOSE button, the gate is not moving, motor has noise.	Gate moving is not smoothly.	According to the actual situation to adjust the motor or the gate.
Leakage switch tripped.	Power supply line short circuit or motor line short circuit.	Check wiring.
Remote control working distance is too short.	Signal is blocked.	Connect external receiver antenna, 1.5 meters above ground.
The gate moves to the middle position to stop or reverse.	<ol style="list-style-type: none"> 1.Motor output force is not enough. 2.Sensitivity of obstacle is too high. 3.Gate meets obstacle. 	<ol style="list-style-type: none"> 1.Check whether the transformer power is normal, if not, change the transformer. 2.Adjust the TR2. 3.Remove the obstacle.

Warranty

Warranty Ordinance

1. To repair against this warranty card and invoice during the warranty period.
 2. Warranty period: 1 year after the date of invoice.
 3. Without unauthorized dismantling, any product broken or damage due to quality problem, we'll offer the repair service for free or replace for free.
 4. The malfunction and damages caused by incorrect use or man fault is not covered by this warranty.
-

Maintenance Record

Check Date	Check Content	Maintained by